

PRODUCT INFORMATION PACKET



Model No: CEQ500
Catalog No: CEQ500
5.0 HP Pool Pump Motor, 1 phase, 3600 RPM, 230 V, 184JMZ Frame, ODP
Pool Pump Motors



Regal and Century are trademarks of Regal Rexnord Corporation or one of its affiliated companies.
©2021 Regal Rexnord Corporation, All Rights Reserved. MC017097E





Nameplate Specifications

Output HP	5.0 Hp	Output KW	3.7 kW
Frequency	60 Hz	Voltage	230 V
Current	22.2 A	Speed	3501 rpm
Service Factor	1.15	Phase	1
Duty	Continuous	Insulation Class	F
Frame	184JMZ	Enclosure	Drip Proof
Thermal Protection	Manual	Ambient Temperature	40 °C
UL	Recognized	CSA	Y
CE	Y	Number of Speeds	1

Technical Specifications

Electrical Type	Capacitor Start Capacitor Run	Starting Method	Across The Line
Poles	2	Rotation	Selective Counterclockwise
Mounting	Special/Non-Standard	Motor Orientation	Horizontal
Drive End Bearing	Ball	Opp Drive End Bearing	Ball
Frame Material	Rolled Steel	Shaft Type	7/8 Keyed
Overall Length	17.11 in	Frame Length	10.50 in
Shaft Diameter	1.000 in	Shaft Extension	4.25 in
Connection Drawing	005056.03CY	Outline Drawing	OLCEQ500

This is an uncontrolled document once printed or downloaded and is subject to change without notice. Date Created:10/07/2021

VIEW FROM OUTSIDE OF MOTOR AT SWITCH END.

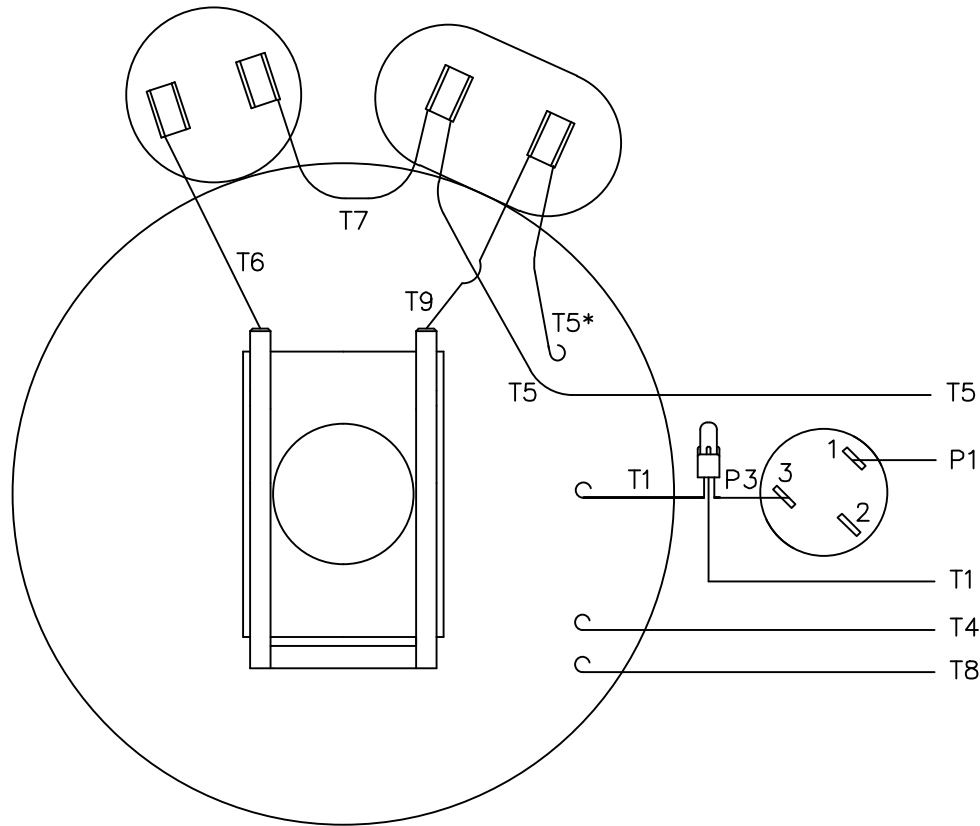

* THIS LEAD MAY BE WHITE

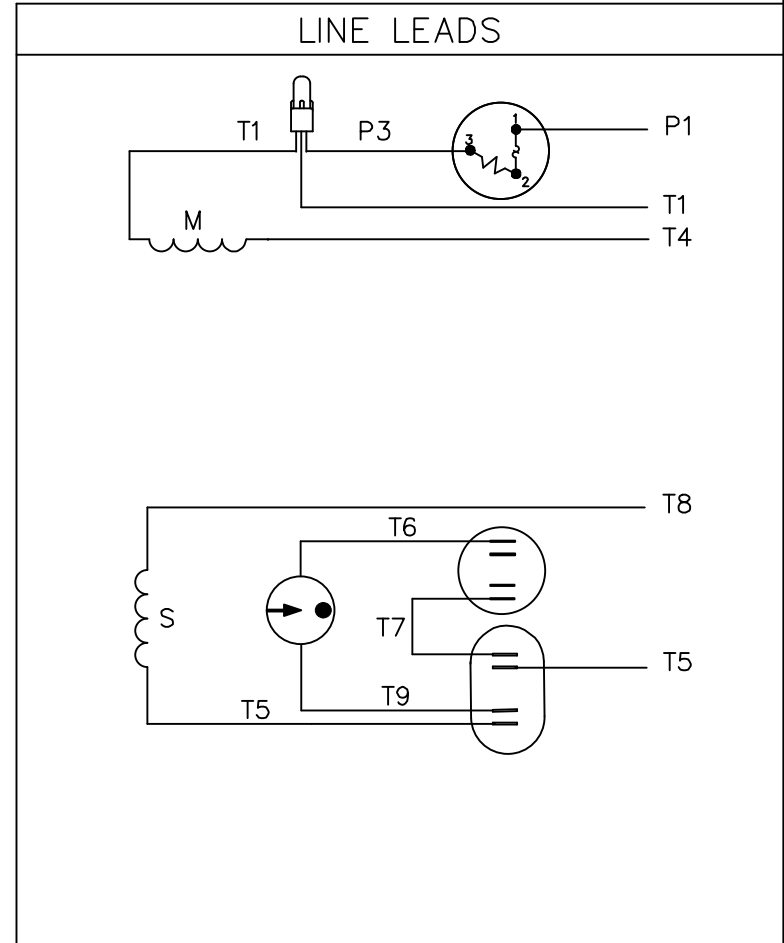

ROTATION FACING LEAD END	L1	L2	JOIN
C.C.W.	P1	T4, T5	T1, T8
C.W.	P1	T4, T8	T1, T5

		TOLERANCES UNLESS SPECIFIED	
		DEC.	INCHES
		.X	±.1
		.XX	±.01
		.XXX	±.005
		.XXXX	±.0005
NO.	REVISION	BY & DATE	CHK ANG ±1/2'



TITLE	EXTERNAL WIRING DIAGRAM TYPE "K" W/ PROTECTOR	DRAWN	GR 08/08/12
MAT'L.	DECAL - 004015	CHK	SR 08/08/12
FINISH		APPD	
		SCALE	1=1
		REF	005056-03
		FMF	
		PREV	

THIS DRAWING IN DESIGN AND DETAIL IS OUR PROPERTY AND MUST NOT BE USED EXCEPT IN CONNECTION WITH OUR WORK ALL RIGHTS OF DESIGN AND INVENTION ARE RESERVED THIS IS AN ELECTRONICALLY GENERATED DOCUMENT - DO NOT SCALE THIS PRINT

RFP	CAD FILE	00505603CY	SIZE	DRAWING NO.	REV.
DIST	BRF-NLV		A	005056-03CY	