

Paramount Cleaning System

OWNER'S MANUAL

For PCC2000, PV3, Cycleclean, Pool Valet,
Vantage, Vanquish, Step Clean,
SwingSweep and EcoPool

 *Powered by:*
Paramount
Pool Life. Simplified.

004-027-8742-00 REV011312

295 East Corporate Place • Suite 100 • Chandler, AZ 85225
Toll Free: 1.800.621.5886 • Phone: 480.893.7607 • Fax: 480.753.3397
Paramount@1Paramount.com • www.1Paramount.com

TABLE OF CONTENTS

Congratulations!	3
What You Need to Know	3
What is a Water Valve?	4-5
Unique Water Valve Features	6
Water Valve Parts Breakdown.....	7
Water Valve Instructions	8
How to Open the Water Valve	8
Module Installation (6-port).....	9-10
Module Installation (2-port, 3-port, 4-port).....	11-12
Alignment Guide	13
How to Close the Water Valve.....	14-15
Run/Pause Switch	15
Warranty.....	16-17
Nozzles (Cleaning Heads).....	18
Nozzle Removal Installation	19
Optional Paramount Debris Canister	22
Relationship with Pool Equipment.....	23
Cleaning Systems Powered by the Filter Pump.....	23
Cleaning Systems Powered by a Booster Pump	24
Filters.....	24-25
Valves for a single Pump System	25
Chlorinators, Tablet or Salt Systems, Ozone, Solar	25-26
Operating Instructions	27
Trouble Shooting Guide for Paramount In-Floor Systems....	28-30

Copyright © 2012 Paramount Pool & Spa Systems. All Rights Reserved.

Contact Paramount Pool & Spa Systems at 1.800.621.5886

CONGRATULATIONS

Congratulations on your new pool and thank you for choosing one of Paramount's cleaning or circulation systems. This manual will address all of Paramount's systems, the PCC2000, PV3, Cycleclean, Pool Valet, Vantage, Vanquish, Step Clean, Swing Sweep, and Eco Pool. Your system may also include a Paramount debris canister and one or more of Paramount's Drains (MDX-R3, MDX2, MDX, Buzztop Channel Drain and/or SDX).

WHAT YOU NEED TO KNOW

Your system's performance will be maximized by adhering to the following operating instructions, and can be affected by seasonal weather conditions that may require extended periods of operation. The cleaning performance directly relates to the type and design of your specific Paramount system.

It is recommended you call your pool builder or a professional service company if your pool requires attention.

WHAT IS A WATER VALVE?

The Paramount water valve is fully automatic and operates whenever the pump it's connected to is running. Your Paramount Water Valve may be connected to your filter pump or a stand-alone "booster" pump.



The water valve automatically distributes water to different areas of your pool, which can include the floor, steps, benches, spa and water features. It cycles much like an automatic sprinkler system in your yard switching from one circuit to another (Figure 1 shows the combination of water valves). Every water valve has a center port. This is where the water enters the valve. You will have a 2-port, 3-port, 6-port, 9-port or 12-port system depending on the design of your pool. The port count of the water valve indicates the number of circuits that send water back to your pool or to another water valve. Cleaning nozzles or returns are placed at the end of the circuits.

WHAT IS A WATER VALVE? (CONT)

Figure 1

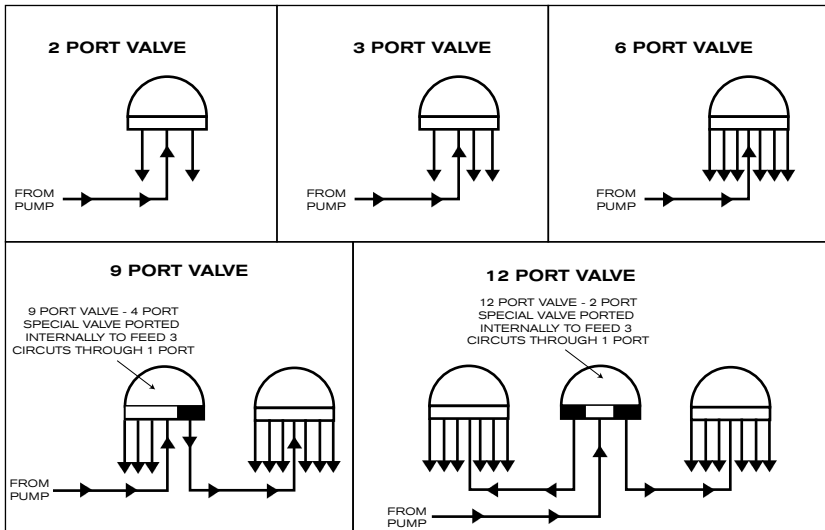

Combination Water Valves (9-Port and 12-Port)

A 9-port system consists of 2 water valves, a 6-port and a 4-port. The 4-port valve has 3 circuits to the pool and 1 circuit that powers the 6 port valve for a total of 9 circuits going to the pool. On this type of system the 3 circuits on the 4-port valve fire twice as often as the other 6 circuits on the six port valve. Your system is designed specifically to take advantage of this firing sequence.

A 12-port system consists of 3 water valves, two 6-ports and one 2-port, 5 gear valve. The 2-port alternately powers each 6-port valve. Your system is designed specifically to take advantage of this firing sequence.

UNIQUE WATER VALVE FEATURES

The run/pause switch on the top of the valve allows you to pause the system to isolate it in an out of the way area of the pool.

The one-piece replacement module design allows easy replacement.

The gauge on your water valve is important and tells you how the system is operating. Gauges should be replaced when they become unreadable or inaccurate. Never use Teflon tape on a replacement gauge, use a thread sealant that is approved for plastic such as Teflon paste. Hand tighten gauge as over tightening can crack the water valve lid.

WATER VALVE BREAKDOWN

Figure 2

Top Dome Complete
Includes Top, Gauge & Pause Assembly:
005-302-4300-03

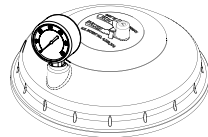

Modules:
005-302-4400-00 2 Port 4 Gear
004-302-4402-00 2 Port 5 Gear
004-302-4404-00 3 Port
004-302-4406-00 4 Port
004-302-4408-00 6 Port

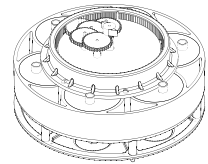

Band Clamp Complete
Includes Knob & Nut:
005-302-3570-00

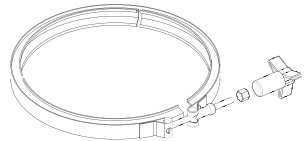

Base O-Ring:
005-302-0100-00

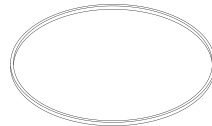

Valve Base (US)*:
005-302-4002-03 2 Port Base 2" Black
005-302-4012-03 3 Port Base 2" Black
005-302-4018-03 4 Port Base 2" Black
005-302-4032-03 6 Port Base 2" Black

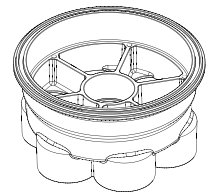

Valve Base (Metric):
005-302-4006-03 2 Port Base 63 mm Black
005-302-4019-03 3 Port Base 63 mm Black
005-302-4020-03 4 Port Base 63 mm Black
005-302-4033-03 6 Port Base 63 mm Black

*US 2" is equivalent to Australian 50 mm.

Pressure Gauge:
005-302-3590-00



Band Clamp Nut:
005-302-0640-00



**Pause Assembly (Includes
Screw Knob, O-Ring & Pawl)**
005-302-3502-00



Band Clamp Knob:
005-302-3600-00



Winterizing Plug:
004-302-1670-00 (Single)
004-302-1672-00 (6 Pieces)



WATER VALVE INSTRUCTIONS

How to open the water valve

1. TURN OFF ALL EQUIPMENT INCLUDING PUMPS. WARNING! FAILURE TO DO SO CAN RESULT IN INJURY OR DEATH.
2. Remove the band clamp by turning the clamp knob or 7/16 inch nut counter-clockwise until it comes off the bolt. Then carefully pull the clamp away from the valve.
3. Lift the top off the base being careful to not lose or stretch the O-ring.
4. Remove the module by lifting up and out of the base.
Note: the module is designed to seal inside the base so it may require a side to side or rocking motion while lifting out. An easy solution is to turn the pump on and off quickly. CAUTION! DO NOT APPROACH THE WATER VALVE WHILE THE PUMP IS ON. FAILURE TO DO SO CAN RESULT IN INJURY OR DEATH.
5. Do not pull the module by the gear mechanism. This can result in damage to the module.

WATER VALVE INSTRUCTIONS (CONT)

Module Installation (6-port)

1. Check the O-ring and groove for debris, and clean if necessary (this is a quad ring and is almost square, the height is slightly bigger than the width).
2. Replace the O-ring if it is stretched or damaged. (Part # 005-302-0100-00) O-ring does not require any lubrication as lubrication can attract dirt and debris that can prevent it from sealing. Never use petroleum jelly on plastic or rubber parts, as this will damage them.
3. Set the module in the base and turn until the alignment pins on the bottom of the module drop into the alignment holes in the base (Figure 3).
4. The module should fit in the base without forcing it. If it does not seat easily then check the following.
 - (Figure 3) shows the piston portion of the current module design approx. 06-2011. These pistons are set at the factory. Do not touch, pull or turn these pistons. Any handling will negatively affect the performance and fit of this product.
 - If the flow optimizer (Figure 4) prevents the module from seating properly in the base you may have to remove it. The flow optimizer has three clips that need to be depressed to remove.

WATER VALVE INSTRUCTIONS (CONT)

Figure 3

MODULE
(BOTTOM VIEW)

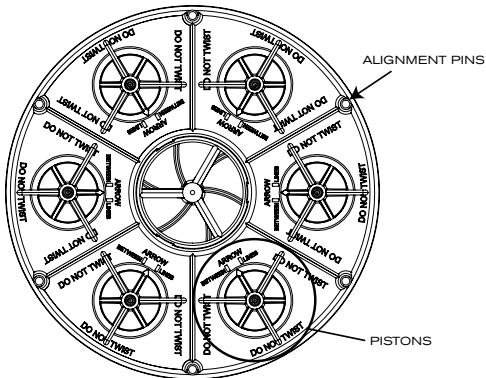

BASE
(TOP VIEW)

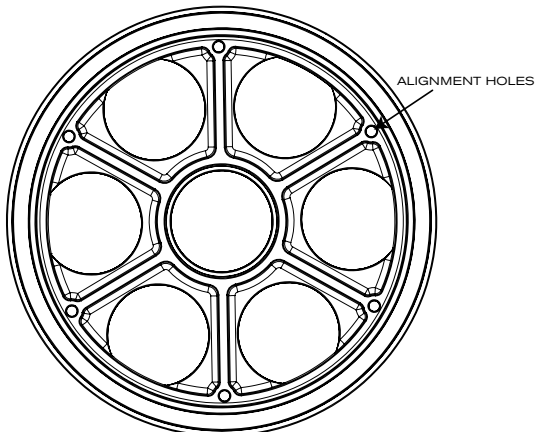

SIDE VIEW

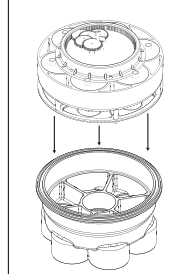
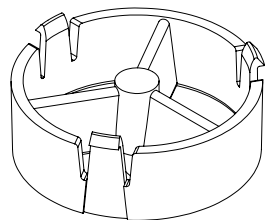

Figure 4



WATER VALVE INSTRUCTIONS (CONT)

Module Installation & Alignment Guide (2-port, 3-port, 4-port)

1. Check the O-ring and groove for debris and clean if necessary (this is a quad ring and is almost square, the height is slightly bigger than the width).
2. Replace the O-ring if it is stretched or damaged. (Part # 005-302-0100-00) O-ring does not require any lubrication as lubrication can attract dirt and debris that can prevent it from sealing. Never use petroleum jelly on plastic or rubber parts, as this will damage them.
3. The module should fit in the base without forcing it. If it does seat easily then check the following.
 - 2-port module alignment – on the 2-port module the ports on top of the module that are attached together by tubes must be centered over the open ports in the valve base (Figure 5).
 - 3-port module alignment – on the 3-port module the ports on top of the module that are attached together by tubes must be aligned over an open port and a closed port section (Figure 5).
 - 4-port module alignment – on the 4-port module the ports on top of the module that are attached together by a tube must be aligned over the half of the base that has only one port (Figure 5).

WATER VALVE INSTRUCTIONS (CONT)

4. Set the module in the base and rotate slightly back and forth until the alignment pins on the bottom of the module drop into the alignment holes in the base (Figure 3).
5. The module should fit in the base without forcing it. If it does not want to seat easily then check the following.
 - (Figure 3) shows the piston portion of the current module design approx. 06-2011. These pistons are set at the factory. Do not touch, pull or turn these pistons. Any handling will negatively affect the performance and fit of this product.
 - If the flow optimizer (Figure 4) prevents the module from seating properly in the base you may have to remove it. The flow optimizer has three clips that need to be depressed to remove.

ALIGNMENT GUIDE

Figure 5

2 PORT 4 GEAR // MODULE & BASE

Used for basin & spa applications, Eco Systems & SwingSweep



Module Part# 004-302-4400-00

Base Part# 005-302-4002-03 (2")
005-302-4006-03 (63mm)

3 PORT // MODULE & BASE

Used for Eco Systems & SwingSweep



Module Part# 004-302-4404-00

Base Part# 005-302-4012-03 (2")
005-302-4009-03 (63mm)

2 PORT 5 GEAR // MODULE & BASE

Used on 12 port systems to feed the two 6 port valves.



Module Part# 004-302-4402-00

Base Part# 005-302-4002-03 (2")
005-302-4006-03 (63mm)

4 PORT // MODULE & BASE

Found on 9 port systems – feeds a 6 port valve.



Module Part# 004-302-4406-00

Base Part# 005-302-4018-03 (2")
005-302-4020-03 (63mm)

6 PORT // MODULE & BASE



Module Part# 004-302-4408-00

Base Part# 005-302-4032-03 (2")
005-302-4038-03 (63mm)

*US notation of 2" is equivalent to Australian 50 mm.

WATER VALVE INSTRUCTIONS (CONT)

How to close the water valve

1. Check the O-ring and groove for debris, and clean if necessary (this is a quad ring and is almost square, the height is slightly bigger than the width)
2. Replace the O-ring if it is stretched or damaged. The O-ring does not require any lubrication as lubrication can attract dirt and debris that can prevent it from sealing. Never use petroleum jelly on plastic or rubber parts, as this will damage them.
3. Place the valve top on the base making sure the pause switch is in the run position. You may rotate the lid in any direction you want.
4. Place the band clamp around the valve shells and put the clamp knob or 7/16 nut on the threaded bolt.
5. Tighten the knob/nut securely. Note: Gently tap the band clamp starting opposite the knob/nut going around both sides. While periodically tightening the knob/nut. Be careful not to over tighten the knob/nut.
6. Turn on the pump and inspect the water valve for leaks. **CAUTION! NEVER** stand over any pool equipment when starting the pump after working on it.
7. If you find leaks, turn off the pump and tighten the band clamp more. If it continues to leak, repeat the above steps. If this doesn't work, replace the O-ring.

WATER VALVE INSTRUCTIONS (CONT)

The Run/Pause control switch

The run / pause control switch is used to stop the cleaning system circuits from cycling. When switched to the pause position, it will stop on the circuit that is up at that time. The run / pause control switch should only be used when you desire the nozzles not in the up position to remain down or while servicing the system.

Figure 6



Note: The run / pause control switch can be used without turning off the pump, but can cause damage to the water valve or module diaphragms if overused. If you frequently use the control switch you should turn off the pump first. Always turn the control switch to the run position when removing and replacing the water valve lid.

Paramount Pool & Spa Systems (PP&SS)
295 E. Corporate Place, Suite 100
Chandler, AZ 85225
1.800.621.5886
www.1Paramount.com



In compliance with the Magnuson-Moss Warranty-Federal Trade Commission Act (Public Law 930637, Paramount Pool & Spa Systems (PP&SS) provides the following limited warranties.

CONDITIONS

This limited warranty shall be subject to the original owner complying with the following conditions:

1. The swimming pool shall be kept full of water at all times except for purposes for repair or maintenance not to exceed five (5) days.
2. The PP&SS system shall be operated by the original owner with reasonable care and necessary maintenance.
3. Registration card must be mailed to PP&SS within thirty (30) days of pool completion.

PP&SS NOZZLE AND BODY (EXCLUDING POOL VALET RETRO) ASSEMBLIES LIMITED LIFETIME MANUFACTURERS WARRANTY

PP&SS warrants to the original owner, materials and equipment to be free of defects for as long as original owner owns pool, determined under this warranty to be for the "Lifetime" ownership by original owner from date swimming pool is plastered or optional interior surface finish applied. The materials and equipment covered under the "Lifetime" warranty are the PP&SS Nozzle and Body Assembly. (PVC plumbing installed, labor, material and all other work performed by contractors is not covered under PP&SS Warranty.)

PP&SS SWINGJETS AND RETROJETS (CARETAKER, CARETAKER 99, GAMMA 3, NET N' CLEAN, POOL VALET RETRO, QUIKCLEAN 1, QUIKCLEAN 2) LIMITED MANUFACTURERS 1-YEAR WARRANTY

PP&SS warrants to original owner, materials, and equipment to be free of defects for a period of one (1) year from date of purchase. The materials, parts, and/or related component parts supplied or distributed by PP&SS are covered under this one (1) year limited warranty. (PVC plumbing installed, labor, material and all other work performed by contractors is not covered under PP&SS Warranty.)

PP&SS MDX² ANTI-ENTRAPMENT DEBRIS DRAIN AND MDX-R3 VGB COMPLI- ANT DEBRIS DRAIN LIMITED MANUFACTURERS 1-YEAR WARRANTY

PP&SS warrants to original owner, materials, and equipment to be free of defects for a period of one (1) year from date of swimming pool start-up. The materials, parts and/or related component parts supplied or distributed by PP&SS are covered under this one (1) year limited warranty. (PVC plumbing installed, labor, material and all other work performed by contractors is not covered under PP&SS Warranty.)

PP&SS STEPCLEAN ASSEMBLIES LIMITED MANUFACTURERS 2-YEAR WARRANTY

PP&SS warrants to original owner, materials, and equipment to be free of defects for a period of two (2) years from date of purchase. The bodies, nozzles, water valve and/or related component parts supplied or distributed by PP&SS are covered under this two (2) years limited warranty. (PVC plumbing installed, labor, material and all other work performed by contractors is not covered under PP&SS Warranty.)

PP&SS DISTRIBUTION WATER VALVE LIMITED MANUFACTURERS 3-YEAR WARRANTY

Paramount water valve module and housing are warranted-for a period of 3 years to be free of manufacturing defects including wear and tear on product from date of pool start-up. This warranty applies to the original pool owner only. Replacement parts thereafter are warranted for a period of 1 year.



U.S. Patents: 3,521,304 • 3,675,252 • 4,188,673 • 4,212,088
4,391,005 • 4,592,379 • 4,939,797 • 5,135,579 • 5,251,343
5,265,631 • 6,301,723 • 6,311,728 • 6,314,999 • 6,360,767
6,367,098 • 6,393,629 • 6,601,244 • 6,810,537 • 6,848,124
6,895,608 • 6,899,285 • 7,055,189 • 7,089,606 • 7,089,607
D,531,888 D,532,684 • 7,178,179 • 7,213,275 • 7,481,377
7,578,010 • 7,708,212 • 7,819,338 • 7,837,951
other U.S. and international patents pending

PP&SS DEBRIS CONTAINMENT CANISTER LIMITED MANUFACTURERS 3-YEAR WARRANTY

PP&SS warrants to original owner, materials, and equipment to be free of defects for a period of three (3) years from date of swimming pool start-up. The materials and equipment covered under this three (3) year warranty is the PP&SS Debris Containment Canister Housing. (PVC plumbing installed, labor, material and all other work performed by contractors is not covered under PP&SS Warranty.) The PP&SS Canister Debris Containment Basket, Internal Canister Lid, and Top Deck Lid are covered for a period of one (1) year under this warranty.

OTHER RELATED SYSTEM PARTS, ANCILLARY PARTS AND REPLACEMENT PARTS LIMITED MANUFACTURERS 1-YEAR WARRANTY

PP&SS warrants to original owner, materials, and equipment to be free of defects for a period of one (1) year from date of swimming pool start-up. The materials, parts and/or related component parts supplied or distributed by PP&SS are covered under this one (1) year limited warranty. (PVC plumbing installed, labor, material and all other work performed by contractors is not covered under PP&SS Warranty.) Replacement parts are warranted for a period of 1 year from the date of purchase.

PP&SS warrants to original owner a one (1) year limited warranty that the PP&SS related component parts to be free of defects from the time of installation.

REPLACEMENT CONDITIONS

This warranty is the responsibility of the owner to remove the PP&SS Nozzle & Body Assembly, Distributor Water Valve Top/Bottom Housing, Debris Containment Canister or other related system components described with this warranty, contact PP&SS for an RMA number, and return it to PP&SS. Ship part in question freight pre-paid, and upon confirmation of defect, PP&SS will repair or replace the PP&SS warranted at no charge to the original owner. The repaired or replaced PP&SS item will be returned to the original owner with freight C.O.D. Labor to reinstall the repaired or replaced item is the sole responsibility of the owner.

LIMITATIONS

No warranty extends to any part of the PP&SS parts or components which is caused by any of the following conditions or events:

1. Defects or failures caused by abuse, lack of responsible care, lack of necessary maintenance, improper operation, vandalism, acts of God.
2. Damages or failures caused by abuse, lack of responsible care, lack of necessary maintenance, improper operation, vandalism, acts of God.
3. PP&SS expressly denies any responsibility or liability for incidental or consequential damages arising out of, or as a result of, use or ownership of your PP&SS parts or as a result of use or ownership of your PP&SS parts or components, or other related products covered under this limited warranty.
4. Any defects caused by acts of God, such as storms, earthquakes, ground movement, or freezing, etc., that are beyond the normal conditions.
5. Installation of the PP&SS System by non-authorized installer may render this warranty null and void.
6. Paramount does not warranty against product fading and/or discoloration.

Some states do not allow the exclusion or limitation of incidental or consequential damages, so the above limitations or exclusions may not apply to you.

Implied warranties are limited in duration to the duration of the written limited warranty here-within. Some states do not allow limitations on how long an implied warranty lasts, so the above limitations may not apply to you.

This warranty give you specific legal rights, and you may also have other rights that may vary from state to state.

NOZZLES (CLEANING HEADS)

All Paramount nozzles are sized and placed specifically for your pool by Paramount. These nozzles have different sized openings and if removed, should be returned to the same location. Switching the nozzle location will result in poor cleaning and could severely damage your pool equipment.

All of your system nozzles must extend and retract completely with each cycle of the water valve. Depending on the cleaning system, it will take 12 to 18 cycles for a nozzle to rotate 360 degree. There are two exceptions to this.

1. The PCC2000 and Vantage systems can have one to three nozzles (called Fixed Nozzles) that stay up all the time the filter pump is on and they do not rotate. These nozzles need to be aimed at the main drain.
2. The optional Swing Jet nozzles are placed on the sidewall of a pool, and rotate back and forth between three positions in a 90-degree arc. They must retract and extend fully to move to the next position.

NOZZLE REMOVAL /INSTALLATION

Nozzles may need to be removed from time to time for purposes of winterizing or to flush debris from the lines and/or nozzles. There are 3 methods of removing the 8 different types of nozzles.

Method 1:

For Vanquish, Vantage and PCC2000 floor nozzles see Figure 7. Using the removal tool common to these nozzles, attach the tool to the end of your pool pole placing it over the nozzle and making sure the tool tabs insert into the nozzle slots. Turn the tool clockwise a $\frac{1}{4}$ turn to unlock the nozzle and then lift it from the body in the floor of the pool. When replacing the nozzle, be sure the body is free from all debris or the nozzle will not lock in place. Make sure the o-ring on the bottom of the nozzle is in place. Lock the nozzle into the tool on the end of your pool pole and replace the nozzle in the body and turn counter clockwise to lock into the body.

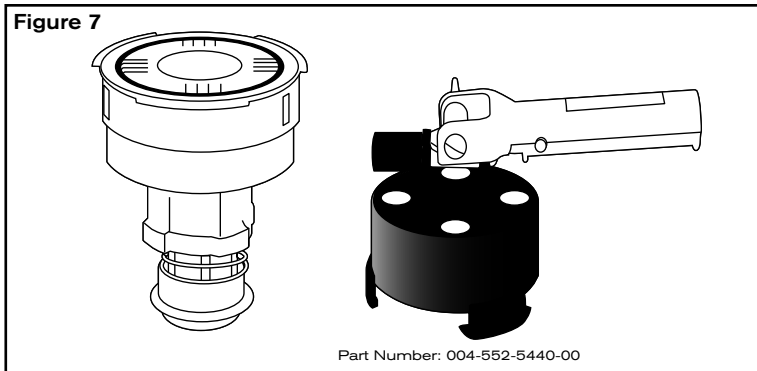

NOZZLE REMOVAL /INSTALLATION (CONT.)

Method 2:

PV3, Cyclean and PCC2000 step nozzles see Figure 8 (Some PCC2000 systems use the large floor nozzle in the steps). See method 1 above for removal and installations instructions. Using the removal tool common to these nozzles, attach the tool to the end of your pool pole placing it over the nozzle and making sure the tool tabs insert into the nozzle slots. Turn the tool counter clockwise a $\frac{1}{4}$ turn to unlock the nozzle and then lift it from the body in the floor of the pool. Make sure the o-ring on the bottom of the nozzle is in place. When replacing the nozzle, lock the nozzle into the tool on the end of your pool pole and replace the nozzle in the body and turn clockwise to lock into the body.

Figure 8

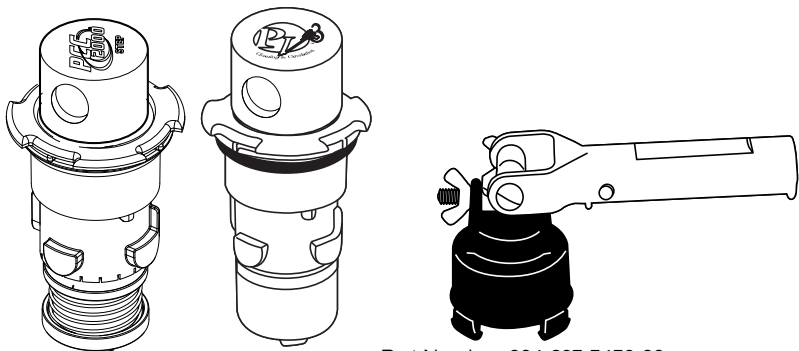

Part Number: 004-627-5452-00

NOZZLE REMOVAL /INSTALLATION (CONT.)

Method 3:

Pool Valet and Step Clean see Figure 9. Using the removal tool common to these nozzles, place the ends of the U-shaped tool in 2 of the slots and turn counter clockwise. This is a threaded retainer ring that will require 3 full turns to remove. If you experience difficulty unscrewing the retainer ring tap on it gently. This is best accomplished by tapping on the top of the tool. The amount of force necessary can vary depending on how long the nozzle has been installed. When replacing the threaded ring of the nozzle wrap it twice with Teflon tape. This will make for easy removal in the future.

NOTE: Sand and pebbles can get between the body and the nozzle and make it very difficult to remove a nozzle. To make the nozzle removal easier, use a pressure nozzle on a garden hose (like you use to clean the side walk) and blow the debris out between the nozzle and body before using the tool to remove the nozzle.

NOTE: The nozzle is specific to the body it came out of. Always put the nozzle back in the same body it came out of.

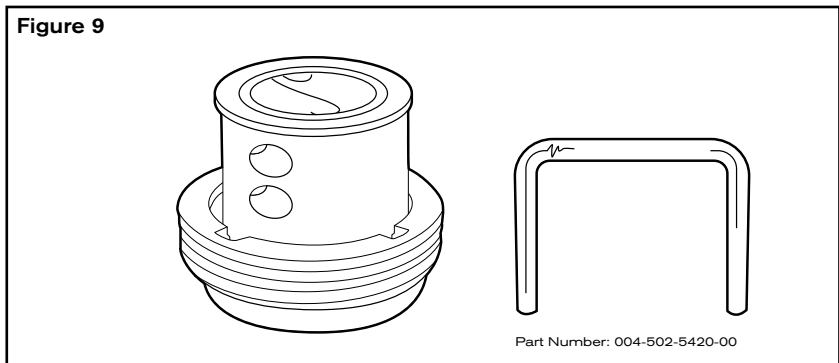

OPTIONAL PARAMOUNT DEBRIS CANISTER

Your pool may be equipped with the Paramount optional debris canister, which would be located in the deck next to your pool. The canister is where the debris from your pool is gathered after it passes through the drain. This debris needs to be emptied from the canister's catch basket/bag regularly. It is important to empty the basket in the leaf canister on a regular basis, just like your skimmer and pump baskets, so your pool equipment will work to its best efficiency. This canister has patented water sealed easy to remove twist lock lid that needs no O-ring. The Paramount canister's water sealed lid has an equalizer running from the canister to the pool to keep water on top of the lid. The equalizer line must be kept clear from obstructions.

Paramount offers a high capacity stainless steel replacement basket for your debris canister. Part number 005-152-8031-00.

RELATIONSHIP WITH POOL EQUIPMENT

Cleaning Systems Powered by the Filter Pump

1. Pumps must be capable of maintaining 20 psi /138 kPa on the water valve(s) pressure gauge.
2. Your pump must be capable of maintaining 20 psi/138 kPa at the water valve regardless of the additional features on your pool such as spas, solar heating systems, heat pumps, water features, chlorinators, or any other device that is powered by your pump.
3. Adding items to your filter system after construction (solar, heat pumps, water features, chlorinators, and any thing that takes pressure away from the nozzles) will have a negative effect on the cleaning system. Please contact your builder or Paramount before adding these items.
4. Keeping your filter clean is required to maintain the 20 psi /138 kPa at the water valve. A dirty filter will prevent your system from cleaning the pool.
5. The in-floor system comes with a pressure gauge on the water valve and although the system may operate at lower psi, the best cleaning results require 20 to 24 psi/138-165 kPa at the water valve pressure gauge. You will see reduced performance if the system is operated at less than ideal pressure.
6. The systems cleaning cycle is determined by many factors (landscape, temperature, weather and condition of pool equipment). To determine your cleaning cycle, run the pool until it is clean. In extreme conditions an extended cycle will be necessary.
7. It is important to keep the skimmer and pump basket(s) empty, so

RELATIONSHIP WITH POOL EQUIPMENT (CONT.)

your pool equipment will power your in-floor system. Failure to do so will negatively affect the performance of your system.

8. When cleaning your cartridge or D.E. Filter care must be taken before removing the filter elements that the filter tank be drained and rinsed out. This is required to prevent dirt and debris from entering the return line and getting into your in-floor system or any other down-line components.

Cleaning Systems Powered by a Booster Pump

1. Because booster pump systems are designed to pull from the skimmer(s) and not use a filter, they are not affected by the typical reductions in performance that affect filter pump systems. Booster pumps need to produce a minimum of 65 gpm/246 lpm at 60 ft./179kpa of head.
2. It is important to keep the skimmer and pump basket(s) empty, so your pool equipment will power your in-floor system. Failure to do so will negatively affect the performance of your system.

Filters

1. A clean pool filter is necessary for optimum system performance. Your pool filter needs cleaning when your filters pressure increases 5 psi / 34 kPa above the pressure showing when your filter is clean.
2. If the need arises to replace your filter and/or its backwash valve it is important that they are properly sized.

RELATIONSHIP WITH POOL EQUIPMENT (CONT.)

- Sand Filter minimum size 4.9 square feet / .46 square meters
- D.E. Filter minimum size 48 square feet / 4.5 square meters
- Cartridge Filter minimum size 200 square feet / 19 square meters
- Backwash Valve minimum size 2 inch or 63 mm Europe
- Backwash Valve minimum size 2 inch or 50 mm Australia_

NOTE: Larger filter sizes will reduce the amount of cleaning needed.

NOTE: Be sure your replacement filter is adequately sized for your existing pump.

Valves for a Single Pump System

1. The skimmer suction should be restricted to make the main drain pull more, because water takes the path of least resistance, and in-floor systems do most of their cleaning from the main drain
2. Returns, spa over flows, and water features must be turned off or restricted on single pump system so that the in-floor system will have proper pressure. Minimum 20 psi / 138 kPa is needed to run the system.

Chlorinators, Tablet or salt systems, Ozone units and Solar Systems

1. Cells on salt chlorinators must be kept clean. Failure to do so will reduce the performance of your in-floor cleaning system.
2. If you add a salt chlorinator after your pools construction it is

RELATIONSHIP WITH POOL EQUIPMENT (CONT.)

recommended to put cells on a bypass loop.

3. Any device that uses a venturi injection system on the return side of the filter is not recommended on single pump in-floor system.
4. Solar systems on a single pump require a specific plumbing method, which includes a small booster pump for the solar system (Figure 10).

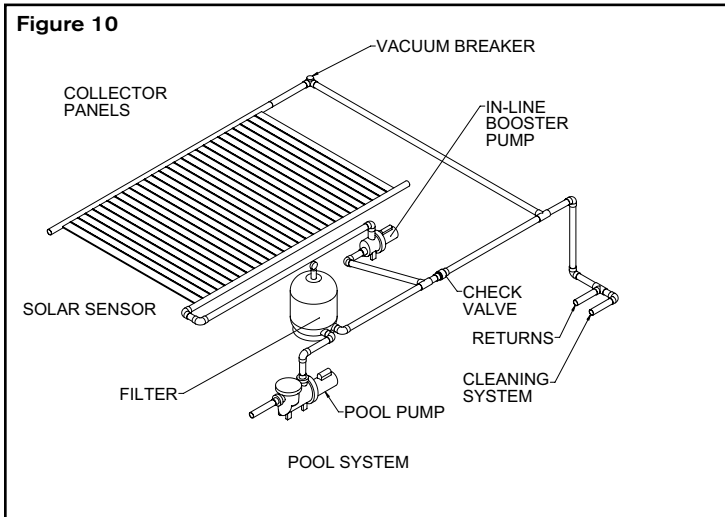

OPERATING INSTRUCTIONS

1. On all Paramount in-floor cleaning and circulation systems it is important to keep the skimmer, the pump and the debris canister baskets clean. It is also important to clean your filter when the pressure rises 5 psi / 34 kPa over the clean starting pressure.
2. The gauge on your water valve is important and tells you how the system is operating. Gauges can deteriorate over time and should be replaced when they become unreadable or inaccurate. Never use Teflon tape on a replacement gauge, use a thread sealant that is approved for plastic such as Teflon paste. Hand tighten gauges as over tightening can crack the water valve lid.
3. If a nozzle is stuck open or up when the pump shuts off you may clear it by pushing down on it a few times while it is on to clean it out.
4. No cleaning system is 100%. Paramount's in-floor guarantee is the strongest in the industry but some attention to the pool is required to keep your backyard oasis beautiful. You must keep your chemicals at proper levels, and brush any small areas that may have a build up of heavy sand or debris. Keep in mind that when excessive debris gets into a pool, such as large amounts of leaves in the fall or dirt during a dust storm, no cleaning system can do the job without some help, so be sure your equipment is maintained.
5. On PCC and Vantage systems that may have fixed nozzles they may need to be adjusted to keep their flow of water aimed in the direction of the debris drain. These nozzles can be turned clockwise when in the up position by pushing down slightly and rotating them towards the main drain.

For further instructions see trouble shooting guide in this manual.

TROUBLE SHOOTING GUIDE FOR PARAMOUNT IN-FLOOR SYSTEMS

Problem	Diagnosis	Solution
<p>Cleaning nozzles/s are staying up when the pump is off</p>	<p>Cleaning nozzles could be jammed with sand or debris which could result from improper cleaning of your pool filter. See section Paramount's systems relationship to your pool's equipment.</p>	<p>Isolate the circuit of the jammed or stuck cleaning nozzles using the pause switch on your water valve. With the system pump running .Push the cleaning nozzles down repeatedly with your foot or pool pole.</p>
<p>Cleaning nozzles on a circuit stay up once the water valve has switched to the next circuit but retract when the system is off.</p>	<p>A circuit in the water valve is staying open due to a jammed piston in the module. This could be caused by debris entering the water valve.</p> <p>NOTE: PCC AND VANTAGE BOOSTER PUMP SYSTEMS MAY HAVE FIXED NOZZLES ON THE FILTER PUMP WHICH STAY UP WHILE THE FILTER PUMP IS ON.</p>	<p>Remove the module from the water valve (see module removal procedure) clean it by holding it in the pool sideways and move it back and forth quickly until it is clean. If there are any pistons in the open position, push them shut being sure not to rotate them. Place the module back in the water valve (see module installation procedure) and turn the system pump on to determine if the cleaning nozzles are now functioning properly. Depending on the age of the module, if this does not solve the problem it may be time to purchase a new module.</p>

It is always best to call a trained professional to service your pool

Further information on your cleaning system can be found at: www.1paramount.com

TROUBLE SHOOTING GUIDE FOR PARAMOUNT IN-FLOOR SYSTEMS

Problem	Diagnosis	Solution
System is not cleaning as it used to.	Check for minimum operating pressure of 20 psi / 138 kPa on the water valve.	Check the run time of your in floor system. It may need to be extended. Especially during increased demand due to weather conditions or bather load. Refer to the section titled "Paramount's systems relationship to your pool's equipment". If after following these steps and the problem still exists call a trained professional to service your pool.
System is not cleaning as it used to.	Pool drain is plugged.	With the filter pump and booster pump (if applicable) both running adjust your valves on the filter pump to draw 100% from the pool drain. If your filter pump becomes noisy (cavitates) your pool drain may be obstructed. At this point call a trained professional to service your pool.
An area around one nozzle that is going up and down is not being cleaned.	Cleaning nozzle is partially or completely blocked.	Refer to the Nozzle / Installation and Removal section. Remove the nozzle. With the nozzle removed turn on the system pump to blow out the circuit. Check the nozzle for debris stuck inside. Replace the nozzle.

It is always best to call a trained professional to service your pool

Further information on your cleaning system can be found at: www.1paramount.com

TROUBLE SHOOTING GUIDE FOR PARAMOUNT IN-FLOOR SYSTEMS

Problem	Diagnosis	Solution
<p>The water valve stays on one circuit evidenced by one circuit of nozzles running constantly and not switching.</p>	<ul style="list-style-type: none"> • Run / Pause switch is in the pause position. • The module gear mechanism could be jammed. • System could have incorrectly sized nozzles • System could have a plugged circuit 	<ul style="list-style-type: none"> • Turn the Run/ Pause switch to run. • Take the module out of the water valve (refer to Water Valve Instructions) Make sure that the gear mechanisms turn freely. If it does not, remove all debris. If it still does not work, replace the module. • Check for pressure above 25 psi / 172 kPa at the water valve. If the pressure does not change or changes very slowly (longer than 3 minutes) and if the nozzle(s) have been removed they may have been replaced in the wrong locations. Nozzle(s) are size and location specific to your system. • Remove nozzle(s) refer to the Nozzle / Installation and Removal section. Turn the system pump on to blow out the circuit. Replace Nozzle(s).

It is always best to call a trained professional to service your pool

Further information on your cleaning system can be found at: www.1paramount.com

POOL INFORMATION

Your Pool Builder will provide the below information upon request:

Pool Builder: _____

Pool Start-up Date: _____

Filter Pressure (After Backwash): _____

Water Valve Pressure (After Backwash): _____

Backwash Filter When Pressure Reaches: _____

Gallons of Water in Pool: _____

Gallons of Water in Spa: _____

NOTES

IMPORTANT INFORMATION ENCLOSED

**CONTAINS:
OWNER'S MANUAL
WARRANTY ACTIVATIONS CARD
WARRANTY CERTIFICATE**



295 East Corporate Place • Suite 100 • Chandler, AZ 85225
Toll Free: 1.800.621.5886 • Phone: 480.893.7607 • Fax: 480.753.3397
Paramount@1Paramount.com • www.1Paramount.com