

# OWNER'S MANUAL

## Commercial Pump

**SPECK**   
pumps

## READ THIS MANUAL CAREFULLY BEFORE USING THE SPECK PUMP

**Important Notice:** This manual contains important information about the installation, operation and safe use of this product. This information should be given to the owner and/or operator of this equipment.

**WARNING:** *This product must be installed and serviced by a qualified pool professional, and must conform to all national, state, and local codes.*

**WARNING:** *Before installing this product, read and follow all warning notices and instructions which are included. Failure to follow safety warnings and instructions can result in severe injury, death, or property damage. Call (800) 223-8538 or visit [www.usa.speck-pumps.com](http://www.usa.speck-pumps.com) for additional copies of these instructions.*

---

## IMPORTANT SAFETY INSTRUCTIONS

---

When installing and using this electrical equipment, basic safety precautions should always be followed, including the following:

### 1. READ AND FOLLOW ALL INSTRUCTIONS.

**2. WARNING** - To reduce the risk of injury, do not permit children to use this product unless they are closely supervised at all times.

**3. WARNING** - Risk of Electrical Shock. Connect only to a branch circuit protected by a ground-fault circuit interrupter (GFCI). Contact a qualified electrician if you cannot verify that a circuit is protected by a GFCI.

**4. WARNING** - To reduce the risk of electric shock, replace any damaged cord immediately.

**5. DO NOT** install within an outer enclosure or beneath the skirt of a hot tub or spa.

**6. CAUTION** - This pump is for use with permanently-installed pools and may also be used with hot tubs and spas if so marked. Do not use with storable pools. A permanently-installed pool is constructed in or on the ground or in a building such that it cannot be readily disassembled for storage. A storable pool is constructed so that it is capable of being readily disassembled for storage and reassembled to its original integrity.

**7.** The unit must be connected only to a supply circuit that is protected by a ground-fault circuit-interrupter (GFCI). Such a GFCI should be provided by the installer and should be tested on a routine basis. To test the GFCI, push the test button. The GFCI should interrupt power. Push the reset button. Power should be restored. If the GFCI fails to operate in this manner, the GFCI is defective. If the GFCI interrupts power to the pump without the test button being pushed, a ground current is flowing, indicating the possibility of an electric shock. Do not use this pump. Disconnect the pump and have the problem corrected by a qualified service representative before using.

**8. TO REDUCE RISK OF ELECTRICAL SHOCK,** A copper bonding connector (8 AWG) is provided for bonding the motor to all metal parts of the swimming pool, spa, or hot tub structure and to all electrical equipment, metal conduit, and metal piping within 5 feet of the inside walls of a swimming pool, spa, or hot tub, when the motor is installed within 5 feet of the inside walls of the swimming pool, spa, or hot tub.

**NOTE:** To installer and/or operator of the Speck Swimming Pool Pump; the manufacturer's warranty will be voided if the pump is improperly installed and/or operated.

### 9. SAVE THESE INSTRUCTIONS!

## SECTION 1 EQUIPMENT OPERATION AND MAINTENANCE

### 1/1 LOCATION

1. Locate the pump as close to the pool as practical. Consult local codes for minimum distance between pool and pump.
2. The piping should be as direct and free from turns or bends as possible, as elbows and other fittings greatly increase friction losses.
3. Place pump on a solid foundation which provides a rigid and vibration-free support so that it is readily accessible for service and maintenance.
4. Though the pump is designed for outdoor use, it is advised to protect the pump from continuous direct heat. Install the pump in a well ventilated location protected from excessive moisture (flooding, sprinklers, rain downspouts, etc.).
5. Protect the pump against flooding and excess moisture, prevent foreign objects from clogging air circulation around motor. All motors generate heat that must be removed by providing proper ventilation.
6. **DO NOT** store or use gasoline or other flammable vapors or liquids in the vicinity of this pump. **DO NOT** store pool chemicals near the pump.
7. **DO NOT** remove any safety alert labels such as **DANGER**, **WARNING**, or **CAUTION**. Keep safety labels in good condition and replace missing or damaged labels.
8. Provide access for future services by leaving a clear area around the pump. Allow plenty of space above the pump to remove lid and basket for cleaning.

### 1/2 INSTALLATION

1. When connecting pipework to pump unions, it is recommended that multi-purpose PVC glue is used. Let the glue joint dry overnight.
2. When installing the pump, care should be taken to see that the suction line is below water level to a point immediately beneath and in front of the pump to ensure quick priming via a flooded suction line. Should it not be possible to lay the pipework giving a flooded suction, then a check valve should be fitted in the vertical section of the suction line. The check valve will ensure that the water in the pump starts priming. (*Does not apply to flooded suction applications.*)
3. Suction and discharge line should be independently supported at a point near the pump to avoid strains being placed on the pump.
4. It is advisable to install a gate valve in both the suction and discharge line in the event that the pump must be removed for servicing. (*Flooded suction application only*)

5. Before starting the pump for the first time, remove the see-through lid. (Turn lid ring counterclockwise to remove.) Fill strainer tank with water until it is level with the suction inlet. Replace lid with locking ring. *Hand-tighten* the lid to make an air-tight seal. **DO NOT use any tools to tighten the lid.**

6. When installing and using the motor, basic safety precautions should be done by a licensed electrician in accordance with local codes. Be certain that the motor frame is grounded. Motor name plate has voltage, phase, ampere draw and other motor information as well as wiring connection instructions.

**BONDING:** As required by National Electrical Code Article 680-22, the pump motor must be electrically bonded to the pool structure (reinforced bars, etc.) by a solid copper conductor not smaller than #8 AWG (8.4 mm<sup>2</sup>) wire via the external copper bonding lug on the pump motor.

**GROUNDING:** Permanently ground the pump motor using a conductor of appropriate size. Connect to the #10 green headed ground screw provided inside the motor terminal box.

**NOTE:** Models 95-VIII single phase and Model 95-VIII 2-speed are thermally protected. All other models requires a motor starter.

**NOTE:** **DO NOT** connect to electric power supply until the unit is permanently grounded

Figure 1.0

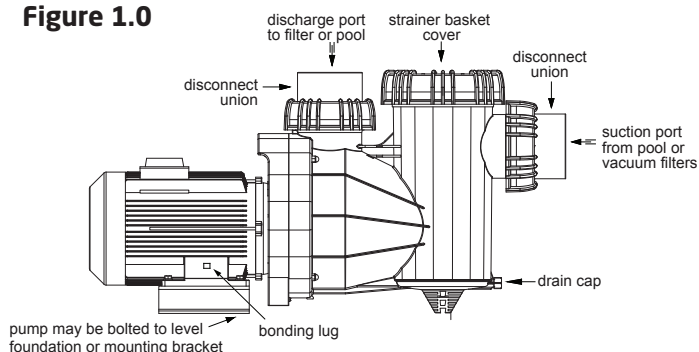

### 1/3 MAINTENANCE

The pump requires little or no service other than reasonable care and periodic cleaning of the strainer basket. **DO NOT** strike basket to clean. When cleaning the basket inspect the lid o-ring for damage and replace if necessary.

**NOTE:** It is normal for a few drops of water to escape from the mechanical seal from time to time. This is especially true during the break-in period.

## SECTION 1 EQUIPMENT OPERATION AND MAINTENANCE

### 1/3 MAINTENANCE - continued

The mechanical seal may become worn and/or loose during the course of time, depending on the running time and water quality. If water continually leaks out, a new mechanical seal should be fitted. After long periods of NON operational (seasonal storage, etc.), the pump must be checked for ease of rotation while it is switched off.

**WARNING:** Before servicing the pump, switch off the circuit breakers at the power source. Severe personal injury or death may occur if the pump starts while your hand is inside the pump.

Place a screwdriver, allen wrench or appropriate tool in the end of the motor shaft and turn it clockwise. *OR* Remove the fan cover and turn the fan in a clockwise direction manually. This may require removal of the cover at the rear of the motor or small circular cap at the rear center of the motor.

#### To Replace the Mechanical Seal

To replace the mechanical seal, remove the sixteen (16) bolts holding the casing to the seal housing. Slide the motor part including the seal housing out. Remove the terminal cover from the rear of the motor and secure the center motor shaft with a 1/2" wrench. Remove impeller nut by turning it counter-clockwise when facing it. Pull the impeller from the motor shaft noting the position of the seal. Remove the seal from the impeller shaft.

### 1/3 MAINTENANCE - continued

To re-assemble, reverse the process. Use only water as a lubricant to install both sides of the seal. Make sure both sides of the seal (ceramic and spring portion) are clean. Gently wipe polished faces with soft and dry cotton cloth. Surfaces can easily be damaged by dirt and scratching. (Use a drop of loc-tite to secure the impeller nut.)

### 1/4 WINTERIZING

**CAUTION:** The pump must be protected when freezing temperatures are expected. Allowing the pump to freeze will cause severe damage and void the warranty.

There are two options when winterizing the pump:

**Option 1:** Drain all the water from the pump, system equipment, and piping. Remove drain plug(s). **DO NOT** replace plug(s). Store plug(s) in the strainer basket for winter. Keep the motor covered and dry.

**Option 2:** Drain all the water from the pump, system equipment, and piping. Remove the pump and motor from the plumbing and store indoors in a warm and dry location.

*NOTE:* When the winter season is over the pump will need to be check and primed prior to start.

**CAUTION: DO NOT** run the pump dry. If the pump is run dry, the mechanical seal will be damaged and the pump will start to leak at the seal. If this occurs, the mechanical seal will need to be replaced. **ALWAYS** maintain the proper water level in your pool. Continued operation in this manner could cause a loss of pressure, resulting in damage to the pump casing, impeller, and mechanical seal.

## SECTION 2 TROUBLESHOOTING GUIDE

PROBLEM	POSSIBLE CAUSES	SOLUTION
1. Pump will not prime.	a. Suction air leak.	Make sure the see-through lid and o-ring are clean and properly positioned. Tighten see-through lid (hand tight). Tighten all pipes and fittings on suction side of the pump. Be sure water in the pool is high enough to flow through skimmer.
	b. No water in pump.	Make sure strainer tank is full of water.
	c. Closed valves or blocked lines.	Open all valves in system. Clean skimmer and strainer tank. Open pump and check for clogging of impeller.
	d. Low voltage to motor.	Check voltage at motor. If low, pump will not come up to speed.
2. Motor does not turn.	a. No power to motor.	Check that all power switches are on. Be sure fuse or circuit breaker is properly set. Time set properly? Check motor wiring at terminals.
	b. Pump jammed.	With power off, turn shaft. It should spin freely. If not, disassemble and repair.

## SECTION 2 TROUBLESHOOTING GUIDE - continued

PROBLEM	POSSIBLE CAUSES	SOLUTION
3. Low flow.	<p>a. Dirty filter.</p> <p>b. No skimmer basket.</p> <p>c. Closed valves or blocked lines.</p> <p>d. Suction air leak.</p>	<p>Back wash filter when filter pressure is high, or clean cartridges.</p> <p>Clean skimmer and pump strainer basket.</p> <p>See problem 1.</p> <p>See problem 1.</p>
4. Noisy operation of motor.	a. Bad bearings.	Noise when shaft is turned up by hand. Motor is hot in bearing area when running. Replace bearing.
5. Motor runs hot.	<p>These motors will run hot to the touch, however, this is normal. They are designed that way. Thermal overload protector will function to turn them off if there is an overload or high temperature problem. Excessive heat can be cause by:</p> <p>a. Low voltage.</p> <p>b. Installed in direct sun.</p> <p>c. Poor ventilation.</p>	<p>Increase size of electrical wire. Be sure motor is operating on correct voltage.</p> <p>Shield motor from sun's rays.</p> <p>Do not tighten cover or enclosure motor.</p>
6. Noisy operation of pump.	<p>a. Air leak in suction line. Bubbles in water returning to pool at inlet.</p> <p>b. Restricted suction line due to blockage or under size pipe. Indicated by high vacuum reading at pump suction.</p> <p>c. Foreign matter (gravel, metal, etc.) in pump impeller.</p> <p>d. Cavitation.</p>	<p>Repair leak. Check suction pipe, see-through lid in place? O-ring clean?</p> <p>Remove blockage or increase suction pipe size. Make sure strainer tank is clean. Are all suction valves fully open?</p> <p>Disassemble pump and remove foreign matter from impeller.</p> <p>Improve suction conditions. (Reduce suction life, reduce number of fittings, increase pipe size.) Increase discharge pressure and reduce flow by throttling discharge valve.</p>
7. Motor overload protection "kicks out".	<p>a. Motor is not connected properly.</p> <p>b. Low voltage due to under size wire or low incoming voltage.</p> <p>c. Wrong size heaters in protective device.</p> <p>d. Overload due to binding in pump or wrong size impeller.</p>	<p>Check wiring diagram on motor.</p> <p>Check with volt meter. Increase size of supply wire. Reports low supply voltage to power company. Voltage at motor must be within 10% of motor nameplate voltage.</p> <p>Heaters should be one size larger than full load amps shown on motor nameplate.</p> <p>Indicated by high amperage readings on motor, binding shaft. Disassemble unit and correct.</p>

## SECTION 3 SERVICING INFORMATION

When calling the manufacturer regarding a question or problem with your pump, please have the serial number available. The serial number is located on the pump either on the flange or motor labels.

Replacement parts may be available from your installer. Call, fax, or write: Speck Pumps at 8125 Bayberry Road, Jacksonville, Florida 32256 Phone: (904) 739-2626 Fax: (904) 737-5261, e-mail: info.usa@speck-pumps.com

# SECTION 4 PARTS AND EXPLODED VIEW

## Model 95-IX & 95-X

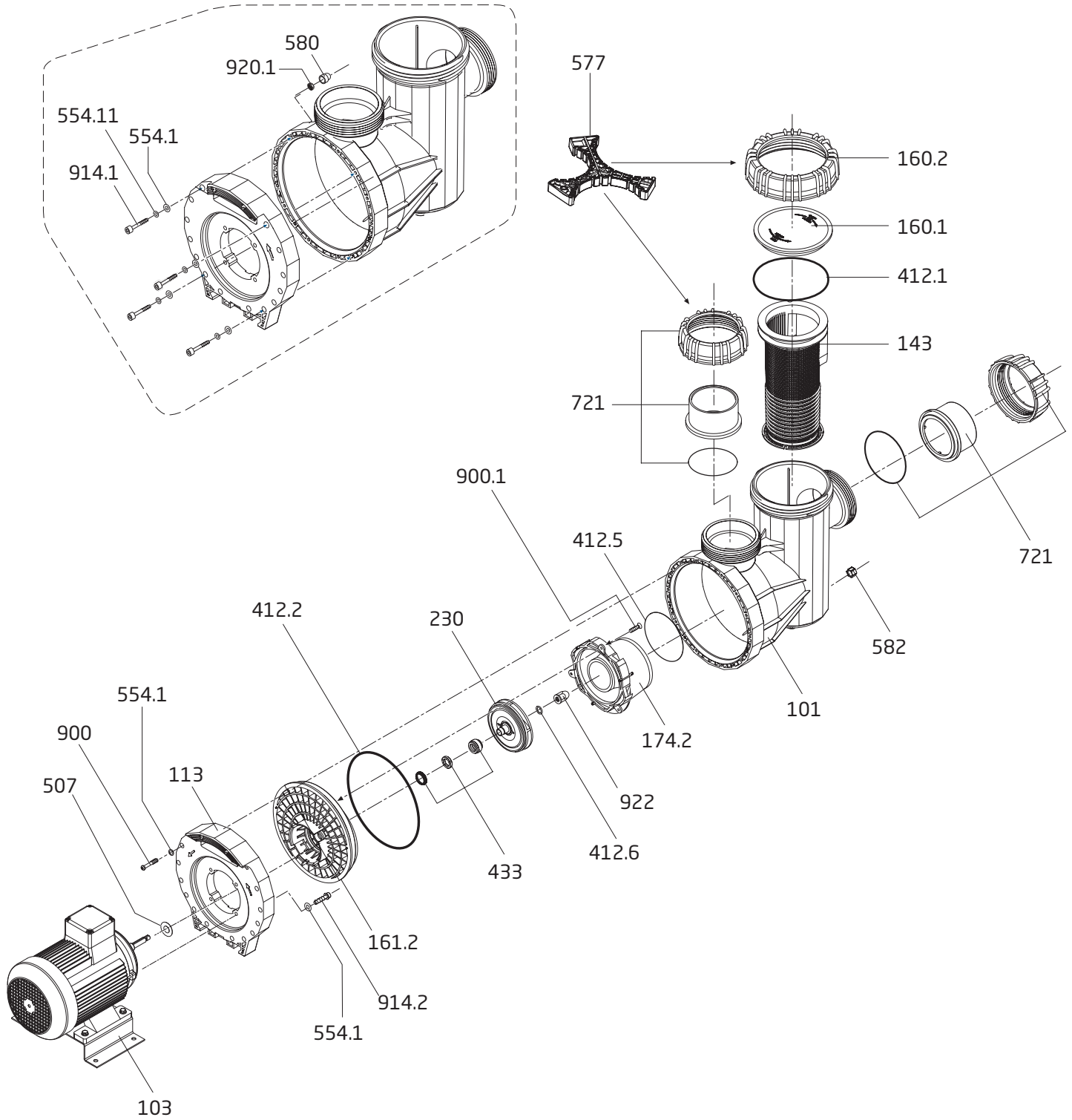

## SECTION 4 PARTS AND EXPLODED VIEW - continued

Order #	Drawing Number	Qty Required	Description
2902016020	160.2	1	LOCK RING - LID
2902016010	160.1	1	LID - CLEAR
2902041210	412.1	1	O-RING - LID 175 x 6.5mm
2902099800	577	1	SPANNER - LID, UNIONS
2902014300	143	1	BASKET - ONE PIECE
2902072154	721	2	UNION HALF PACKAGE - COMPLETE
2901158200	582	1	DRAIN CAP 3/8" WITH GASKET - CASING
2902010158L	101	1	CASING
5879120665	914.1	4	BOLT - CASING M6 x 65mm (ALLEN HEAD)
5871250600	554.11	4	WASHER - CASING BOLT M6
2921192015	920.1	4	NUT - M6 SERRATED - CASING BOLT
2902058000	580	4	PROTECTIVE CAP - CASING BOLT
2902041252A	412.5	1	O-RING - DIFFUSER 123 x 5mm
2902017422	174.2	1	DIFFUSER
2923223025	230	1	IMPELLER (-IX) 5.75 THP (5.0 HP S.F. 1.15) 115-122/20mm
2902023008	230	1	IMPELLER (-X) 8.6 THP (7.5 HP S.F. 1.15) 3 PHASE 127/20mm
2923223037	230	1	IMPELLER (-X) 8.6 THP (7.5 HP S.F. 1.15) 1 PHASE 125/20mm
2923541229	412.6	1	O-RING - SHAFT 16.9 x 2.75mm
2902041220	412.2	1	O-RING - CASING 265 x 6mm
2923592200	922	1	NUT - IMPELLER - PLASTIC W/ BRASS INSERT M12
2920343310	433	1	MECHANICAL SEAL (20mm) COMPLETE
2902016122	161.2	1	SEAL HOUSING 135mm
5879120835	914.2	4	BOLT - MOTOR ALLEN HEAD M8 x 35mm
5871250800	554.1	20	WASHER - MOTOR BOLT - CASING SCREW 8.4mm
2902011300	113	1	FLANGE
2920850702	507	1	SLINGER (SPLASH RING) 45 x 18 x 4mm
5879825522	900.1	3	SCREW - DIFFUSER 5.5 x 22mm
2921690002	900	12	SCREW - CASING - ALLEN HEAD M7 x 48mm
2923000003	103	1	MOTOR BASE
2991000150	NOT SHOWN	1	SOCKET WRENCH EXTENSION TOOL

---

## SECTION 5 LIMITED WARRANTY

---

Speck Pumps-Pool Products, Inc. grants solely to the original consumer purchaser ("Buyer") of the pump and motor the following personal, non-transferable and limited warranty on the following terms and conditions (the "Limited Warranty"): the pump and motor is warranted to be free of material defects in materials or workmanship under normal use for a period of two (2) year beginning on the date of the Buyer's purchase of the pump and motor. Notwithstanding any provisions herein to the contrary, the warranties and obligations hereunder shall not in any event extend for more than three (3) years beyond the date of shipment of the pump and motor from the factory (the "Limited Warranty Period"). The Limited Warranty is subject to each of the following additional terms and conditions:

**1. IN THE EVENT OF ANY BREACH OF THE LIMITED WARRANTY, SPECK PUMPS - POOL PRODUCTS, INC.'S ENTIRE OBLIGATION AND LIABILITY TO BUYER, AND BUYER'S SOLE AND EXCLUSIVE REMEDY SHALL BE AS FOLLOWS:** Speck Pumps - Pool Products, Inc. will, at its option, either repair or replace the pump and motor or refund to Buyer the purchase price actually paid by Buyer for the pump and motor subject to the Limited Warranty. Speck Pumps - Pool Products, Inc. shall have no obligations under the Limited Warranty unless Buyer delivers timely written notice to Speck Pumps - Pool Products, Inc. of the Limited Warranty claim within the Limited Warranty Period and returns the pump and motor to Speck Pumps - Pool Products, Inc. if requested. To the fullest extent permitted by law, Speck Pumps - Pool Products, Inc. expressly disclaims any liability for, and the Limited Warranty does not include or cover, any labor, costs or other expenses in connection with the removal, transportation, shipment, insurance, replacement, repair, or installation of repaired or replaced parts or for any other costs or expenses or damages to property or things including, but not limited to, those arising in connection with the use of, or inability to use, the pump and motor.

2. To the fullest extent permitted by law, the Limited Warranty will be void and of no force or effect and Speck Pumps - Pool Products, Inc. will have no liability, responsibilities or obligations to Buyer or with respect to the pump and motor in the event of the occurrence of any one or more of the following:

- (a) Any damage to the pump and motor caused by Buyer, any third party, ground movement, other natural forces, acts of God or any other sources or causes not arising from a breach of the Limited Warranty, excluding ordinary wear and tear;
- (b) Any replacement, modification, alteration or repair of any parts or components of the pump and motor by anyone other than Speck Pumps - Pool Products, Inc.;
- (c) Any abuse, misuse, accident, tampering with, improper installation or modification of the pump and motor or any other actions, inactions or failures to act that violate the terms and conditions of this Limited Warranty;
- (d) Buyer's failure or inability to present an invoice, bill, receipt or other documentation clearly evidencing that the pump and motor was installed and maintained in strict compliance with this Limited Warranty and that the claim was timely submitted within the Limited Warranty Period; and/or
- (e) Buyer's failure to comply with the conditions and contingencies set forth in paragraph 3 below.

3. The Limited Warranty is expressly conditioned and contingent upon Buyer's strict compliance with each of the following:

- (a) Installation of the pump and motor by an experienced and qualified pool industry professional and a licensed electrician who is licensed within the jurisdiction in which the pump and motor is installed and will be used; and
- (b) Buyer's operation and maintenance of the pump and motor in strict accordance with Speck Pumps - Pool Products, Inc.'s printed operator/maintenance manuals delivered with the pump and motor.

**4. DISCLAIMER: THE LIMITED WARRANTY IS THE ONLY WARRANTY MADE AND IS IN LIEU OF ALL OTHER WARRANTIES, AND ANY AND ALL IMPLIED WARRANTY OR CONDITION OF MERCHANTABILITY, THE IMPLIED WARRANTY AGAINST INFRINGEMENT, AND THE IMPLIED WARRANTY OR CONDITION OF FITNESS FOR A PARTICULAR PURPOSE ARE EXPRESSLY LIMITED IN THEIR SCOPE AND DURATION TO THE TWO YEAR TERM OF THE LIMITED WARRANTY SET FORTH HEREIN. SOME STATES DO NOT ALLOW LIMITATIONS ON HOW LONG AN IMPLIED WARRANTY LASTS, SO THE ABOVE LIMITATION MAY NOT APPLY TO THE BUYER.**

---

## SECTION 5 LIMITED WARRANTY - continued

---

5. TO THE FULLEST EXTENT PERMITTED BY LAW, IN NO EVENT SHALL SPECK PUMPS - POOL PRODUCTS, INC. OR ITS OFFICERS, DIRECTORS, EMPLOYEES, SHAREHOLDERS, AGENTS, OR REPRESENTATIVES BE LIABLE FOR ANY SPECIAL, INDIRECT, INCIDENTAL, EXEMPLARY OR CONSEQUENTIAL DAMAGES OR LOSS, INCLUDING TIME, MONEY, GOODWILL, AND LOST PROFITS IN ANY WAY WHICH MAY ARISE HEREUNDER OR FROM THE USE OF OR INABILITY TO USE THE PUMP AND MOTOR OR THE PERFORMANCE OR NONPERFORMANCE OF ANY OBLIGATION UNDER THIS LIMITED WARRANTY. THIS PARAGRAPH, THE WARRANTY DISCLAIMERS IN PARAGRAPH 4 ABOVE, AND THE SOLE AND EXCLUSIVE REMEDY SET FORTH IN PARAGRAPH 1 ABOVE SHALL APPLY EVEN IF SPECK PUMPS - POOL PRODUCTS, INC. HAS BEEN NOTIFIED OF THE POSSIBILITY OR LIKELIHOOD OF SUCH DAMAGES OCCURRING, WHETHER SUCH LIABILITY IS BASED ON CONTRACT, TORT, NEGLIGENCE, STRICT LIABILITY, PRODUCTS LIABILITY OR OTHERWISE, AND EVEN IF ANY REMEDY STATED HEREIN FAILS OF ITS ESSENTIAL PURPOSE. SOME STATES DO NOT ALLOW THE EXCLUSION OR LIMITATION OF SPECIAL, INDIRECT, INCIDENTAL, EXEMPLARY OR CONSEQUENTIAL DAMAGES OR LOSS, SO THE ABOVE EXCLUSIONS AND LIMITATIONS MAY NOT APPLY.

6. This Limited Warranty gives the Buyer specific legal rights, and the Buyer may also have other rights, which vary from state to state.

7. A return merchandise authorization ("RMA") must be obtained from Speck Pumps - Pool Products, Inc. before returning any product. Products returned without an RMA will be refused and returned, unopened, to the Buyer. All returned products are to be sent freight prepaid and insured for Buyer's protection to the manufacturer at 8125 Bayberry Road, Jacksonville, Florida 32256. Under no condition will products be accepted after the expiration of the Limited Warranty Period. Speck Pumps - Pool Products, Inc. shall not bear any costs or risks incurred by Buyer in shipping a defective pump and motor to Speck Pumps - Pool Products, Inc. or in shipping a repaired or replaced pump and motor to Buyer.

### Technical Support:

**Address:** Speck Pumps  
8125 Bayberry Road  
Jacksonville, FL. 32256  
USA

**Hours:** (Monday - Friday) 8:00 am to 5:00 pm EST

**Toll Free:** 800-223-8538

**Phone:** 904-739-2626

**Fax:** 904-737-5261

**Website:** [www.usa.speck-pumps.com](http://www.usa.speck-pumps.com)

<b>Date of Installation:</b>	
<b>Installed by:</b>	
<b>Serial Number:</b>	
<b>For Service Call:</b>	

*Manufactured by Speck Pumps, Jacksonville Florida USA, © 2019 All Rights Reserved.*

This document is subject to change without notice.